

**Typical Features**

- ◆ Fixed input voltage, Isolated & unregulated output, Output power 1W
- ◆ High Efficiency up to 84%
- ◆ Small compact SIP packing
- ◆ No external component required
- ◆ Isolation Voltage 1500VDC
- ◆ Operating Temperature: -40°C~+85°C
- ◆ Plastic Case, meet UL94 V-0 standard



**Test Condition:** Unless otherwise specified, data in the datasheet should be tested under the conditions of inputting nominal voltage, pure resistance rated load and Ta=25°C

**Application Field**

*It could be widely used for instrument, communication, pure digital circuit, general low frequency analog circuit, relay drive circuit, data exchange circuit, etc.*

**Typical Product List**

Model	Input Voltage Range (VDC)		Output Voltage/Current (Vo/Io)		Input Current(mA) Nominal Voltage		Max. Capacitive Load	Ripple & Noise (Max.)	Efficiency (%)	
	Nominal	Range	Voltage (VDC)	Current(mA) MAX./Min.	Full load Typ.	No Load Typ.	uF	mVp-p	Min.	Typ.
FN1-3V3S3V3A	3.3	2.97 - 3.63	3.3	300	433	50	2000	100	70	72
FN1-3V3S05A			5	200	421	50	2000	100	72	74
FN1-3V3S09A			9	110	410	50	2000	100	72	74
FN1-3V3S12A			12	83	347	45	2000	150	73	75
FN1-3V3S15A			15	67	410	50	2000	100	72	74
FN1-3V3S24A			24	42	421	50	2000	120	70	72
FN1-05S3V3A	5	4.5 - 5.5	3.3	300	278	40	2000	100	74	76
FN1-05S05A			5	200	256	34	2000	100	75	77
FN1-05S09A			9	110	263	40	2000	100	78	80
FN1-05S10A			10	100	240	34	2000	100	79	81
FN1-05S12A			12	83	260	40	2000	100	76	78
FN1-05S15A			15	67	260	40	2000	100	76	78
FN1-05S24A			24	42	256	40	2000	120	76	78
NN1-09S05A	9	8.1-9.9	5	200	132	13	2000	100	78	80
FN1-12S3V3A	12	10.8 -	3.3	300	116	18	2000	100	74	76
FN1-12S05A			5	200	101	11	2000	100	79	81

FN1-12S09A		13.2	9	110	108	18	2000	100	78	80
FN1-12S12A			12	83	100	14	2000	100	81	83
FN1-12S15A			15	67	99	13	2000	100	82	84
FN1-12S24A			24	42	104	18	2000	120	78	80
FN1-15S3V3A	15	13.5 - 16.5	3.3	300	93	15	2000	100	74	76
FN1-15S05A			5	200	89	15	2000	100	77	79
FN1-15S09A			9	110	89	15	2000	100	77	79
FN1-15S12A			12	83	82	12	2000	100	78	80
FN1-15S15A			15	67	88	15	2000	100	78	80
FN1-15S24A			24	42	84	15	2000	120	77	79
FN1-24S3V3A	24	21.6 - 26.4	3.3	300	59	10	2000	100	73	75
FN1-24S05A			5	200	52	7	2000	100	79	81
FN1-24S09A			9	111	51	8	2000	100	79	81
FN1-24S12A			12	83	50	7	2000	100	81	83
FN1-24S15A			15	67	52	8	2000	100	78	80
FN1-24S24A			24	42	53	10	2000	120	76	78

To ensure this module operate efficiently and reliably, the minimum output load could not be less than 10% of the nominal load during operation. If the actual output power is too small, please connect a resistor in parallel at the output, the resistance recommended equal to 10% nominal power;

**Input Specifications**

Item	Test Condition	Min.	Typ.	Max.	Unit
Input Overshoot Voltage (1Second.max.)	3.3Vdc Input	-0.7	-	7	VDC
	5Vdc Input	-0.7	-	9	
	12Vdc Input	-0.7	-	18	
	15Vdc Input	-0.7	-	21	
	24Vdc Input	-0.7	-	30	
Input Filter	Capacitor Filter				

**Output Specifications**

ITEM	Working Conditions	Min.	Typ.	Max.	Unit	
Output Power		0.1	--	1	W	
Output Voltage Accuracy	See Regulation Curve (Photo 1)				%	
Load Regulation	10% ~ 100% nominal load	3.3Vdc output	--	--		20
		Other output	--	--		15
Line Voltage Regulation	Input Voltage	3.3Vdc output	--	--	±1.5	

	Change±1%	Other output	--	--	±1.2	
Ripple & Noise①	Nominal input, full load,20MHZ bandwidth	Other Output	--	75	100	mVp-p
		24Vdc Output	--	100	120	
Temperature Drift Coefficient	100% Full Load		--	--	±0.03	%/°C
Output Short Circuit Protection	Not available					

NOTE:① Ripple & Noise Tested by twisted-pair method, for details please check Design and Application Circuit.

②Some parts could only be guaranteed to be within 5s;

**General Specifications**

Switching Frequency	typical	220KHz (Typ.)
Operating Temperature	Refer to Temperature Derating Curve	-40°C ~ +85°C
Storage Temperature		-55°C ~ +125°C
Shell temperature rising when operating	Within Temperature Derating Curve	25°C(Typ.)
Relative Humidity	No condensing	5%~95%
Case Material		Black flame-retardant heat-resistant Plastic(UL94-V0)
Pin Withstand Welding Temp	Distance to case 1.5mm, 10S	300°C MAX
Isolation Voltage	Test 1 minute, leakage current< 0.5mA	1500Vdc
Isolation Capacitor	Input/Output,100KHz/0.1V	20 pF (Typ.)
MTBF	MIL-HDBK-217F@25°C	35X10 <sup>5</sup> Hrs
Product Weight		1.4g(Typ.)
Package	Tube(225*20.5*12.5mm)	43PCS
	Inner Box(542*110*155mm)	3440PCS(Total 80Tubes)

**Packing Dimension**

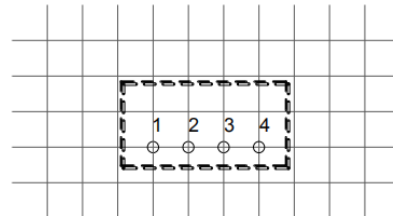
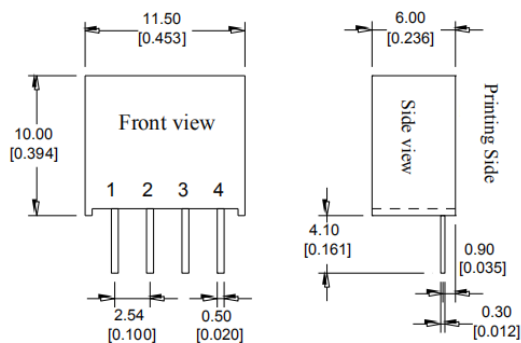

Printed board vertical view

Lattice spacing:2.54mm(0.1inch)

Recommended PCB layout

Packing Dimension

Packing Code	L x W x H	
A	11.50x 6.00 x 10.00mm	0.453 x 0.236 x 0.394inch

**Pin Function**

Single(S)	1	2	3	4
	GND	+Vin	-Vo	+Vo

Note: if the definition of pin is not in accordance with the model selection manual, please refer to the label on actual item.

**Ripple & Noise Test: (Twisted Pair Method 20MHZ bandwidth)**

Test Method:

a. 12# twisted pair to connect, Oscilloscope bandwidth set as 20MHz, 100M bandwidth probe, terminated with 0.1uF polypropylene capacitor and 10uF high frequency low resistance electrolytic capacitor in parallel, oscilloscope set as Sample pattern.

b. Input terminal connect to power supply, output terminal connect to electronic load through jig plate, Use 30cm±2 cm sampling line, Power line selected from corresponding diameter wire with insulation according to the flow of output current.

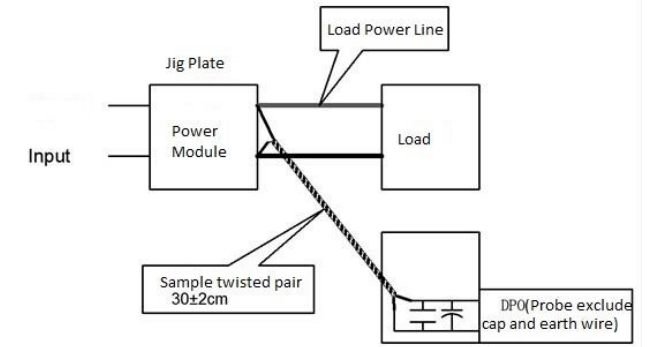

**Product Characteristic Curve**

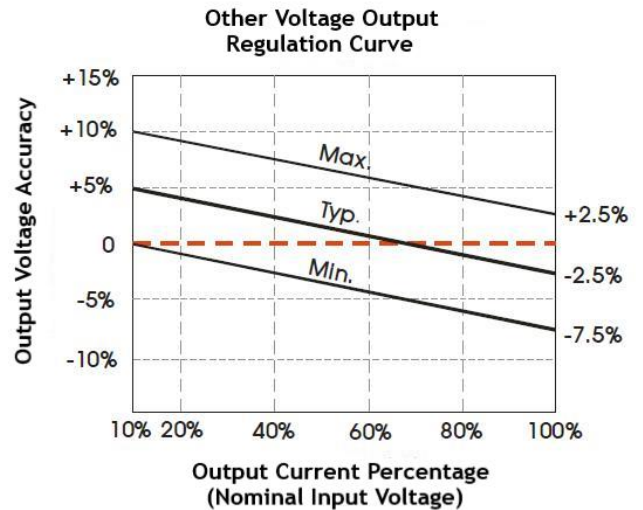
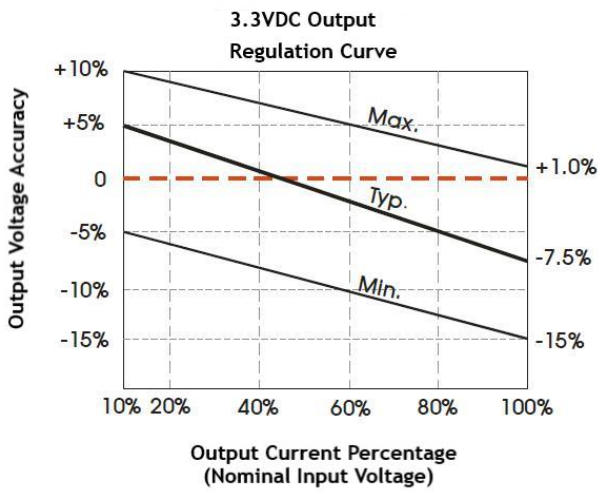

Photo 1

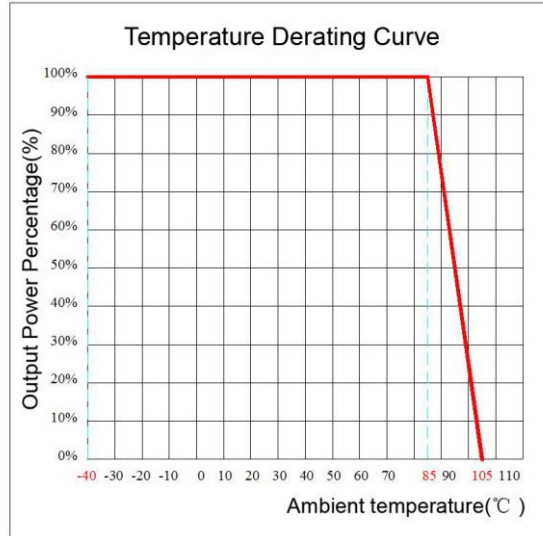
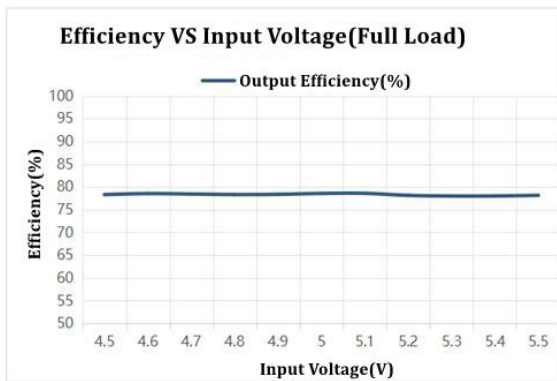
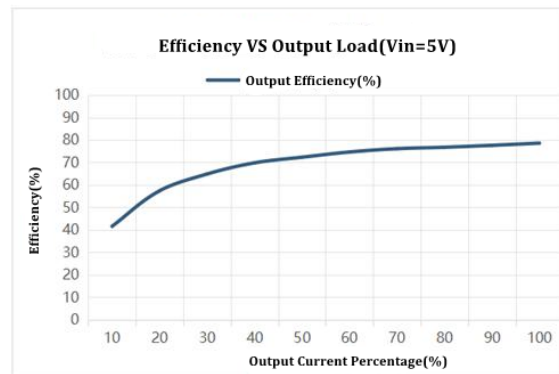

Photo 2



FN1-05S05A



FN1-05S05A

**Design and Application Circuit Recommended**

**1. Output load requirements**

a. In order to ensure the converter can work reliably with high efficiency, the minimum load should not less than 10% rated load when it is used. If the needed power is indeed small, please parallel a resistor at the output side, the resistance equal to 10% nominal load.

b. The maximum capacitive load is tested under nominal input full load, and cannot exceed the maximum capacitive load of output terminal under operation, otherwise it will cause it difficult to start up and damage the product.

**2. Recommended circuit**

In order to ensure the input/output ripple and noise decreased, capacitor filter net could be connected to input and output terminal, application circuit as below photo 3; choosing suitable filter capacitor is very important, start-up problems may be caused by too large capacitance. To ensure the modules running safely and reliably, the recommended capacitive load values as shown in Table 1. (But for the actual output power of application circuit is less than 0.5W, suggest not to connect external capacitor)

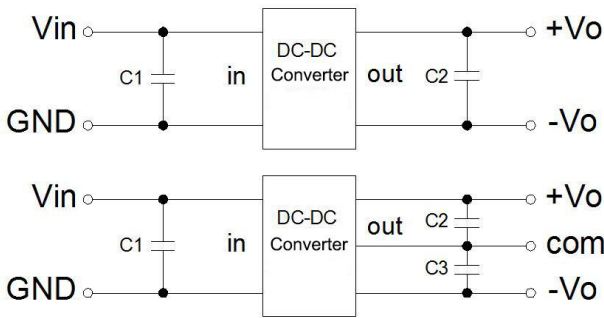

Recommended capacitive load value(Table 1)

Vin (Vdc)	C1 (μF)	Vout (Vdc)	C2 (μF)	Vout (Vdc)	C2,C3 (μF)
3.3/5	4.7	3.3/5	10	±3.3/±5	4.7
12	2.2	9	4.7	±9	2.2
15	1	12	2.2	±12	1
24	1	15	1	±15	0.47
--	--	24	0.47	±24	0.22

3. Output regulated voltage and over voltage protection circuit

The simplest device to protect output regulated voltage, over voltage and over current is to cascade a linear regulator with overheat protection at input or output terminal, and connect a capacitor filter net(see below picture), filter capacitive value recommended see table 1, Linear regulator is chosen according to the actual voltage, current needed in working, or choose our NW series products.

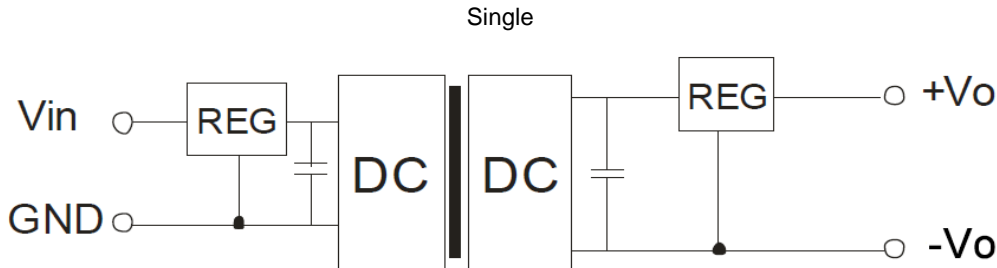

Note:

- 1.This product cannot be used in parallel, and do not support hot-plugging;
- 2.If the product works below the minimum required load, it cannot guarantee that the product performance meets all performance indicators in this manual;
3. All index testing methods in this datasheet are based on our Company's corporate standards
4. The product specification may be changed at any time without prior notice.